

**Modular Cooking Range Line  
 thermaline 90 - 14 lt Well Freestanding  
 Electric Deep Fat Fryer, 1 Side,  
 Backsplash, H=800**

ITEM # \_\_\_\_\_

MODEL # \_\_\_\_\_

NAME # \_\_\_\_\_

SIS # \_\_\_\_\_

AIA # \_\_\_\_\_



**589501 (MCFGFBDDAO)** 14lt electric Deep Fat Fryer, one-side operated with backsplash

### Short Form Specification

**Item No.** \_\_\_\_\_

Unit constructed according to DIN 18860\_2 with 20 mm drop nose top and 70 mm recessed plinth. Internal frame for heavy duty sturdiness in stainless steel. 2 mm top in 1.4301 (AISI 304). Flat surface construction, easily cleanable. THERMODUL connection system enables seamless worktop when units are connected and avoids soil penetrating. Appliance designed to deep fry meat, fish and vegetables (french fries). Deep drawn V-shaped well with external heating elements to facilitate cleaning operations. Indirect oil heating system and uniform heat distribution for extended oil life. Electronic sensor for precise oil temperature control. Reduced power setting to melt solid fat. Oil can be easily drained via a ball-valve. All-round basin raised edges to protect against soil infiltration. Large overflow stamped area around the well. Overheat protection switches off the supply in case of overheating. Standby function saves energy and quickly recovers maximum power. Metal knobs with embedded hygienic silicon "soft" grip enable easier handling and cleaning. IPX5 water resistant certification.  
 Configuration: Freestanding, One-side operated with backsplash.

### Main Features

- Deep drawn V-Shaped well.
- Large overflow stamped area, located around the well.
- External heating elements allow to easily clean the well.
- Overheat protection: the temperature sensor switches off the supply in case of overheating.
- Indirect oil heating system and uniform heat distribution to guarantee extended oil life.
- All major components may be easily accessed from the front.
- Reduced power setting to melt solid fat.
- Oil level mark for MAX/MIN filling.
- Designed for deep fat frying of meat, fish, specialities and vegetable (french fries, chips).
- Oil can be drained off via a ball-valve with a lock to prevent unintentional opening. When opened, the ball valve provides a full cross-section opening to easily clean the drainage system.
- THERMODUL connection system creates a seamless work top when units are connected to each other thus avoiding soil penetrating vital components and facilitating the removal of units in case of replacement or service.
- Metal knobs with embedded hygienic "soft-touch" grip for easier handling and cleaning. The special design of the controls prevents infiltration of liquids or soil into vital components.
- Large visible digital display manufactured in tempered glass to resist heat and chemicals, showing temperatures or power settings. The display also shows on/off status of the appliance and on/off status of the heating elements.
- Raised edge all around the well to protect from infiltration of dirt from worktop.
- Electronic sensor for precise oil temperature control.

### Construction

- 2 mm top in 1.4301 (AISI 304).
- Unit constructed according to DIN 18860\_2 with 20 mm drop nose top and 70 mm recessed plinth.
- Flat surface construction with minimal hidden areas to easily clean all surfaces
- IPX5 water resistance certification.
- Internal frame for heavy duty sturdiness in stainless steel.

### Sustainability



- Standby function for energy saving and fast recovery of maximum power.
- This model is compliant with Swiss Energy Efficiency Ordinance (730.02).

**APPROVAL:** \_\_\_\_\_

Front

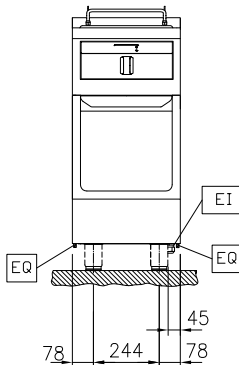

Side

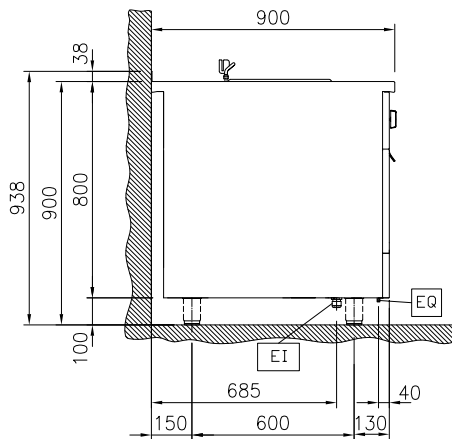

EI = Electrical inlet (power)  
 EQ = Equipotential screw

Top

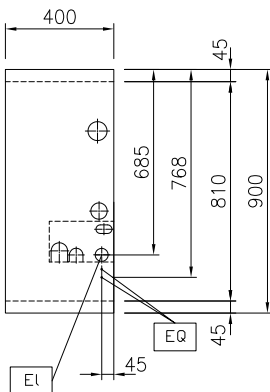
**Electric**

Supply voltage: 400 V/3N ph/50/60 Hz  
 Total Watts: 10 kW

**Key Information:**

Number of wells: 1  
 Usable well dimensions (width): 240 mm  
 Usable well dimensions (height): 225 mm  
 Usable well dimensions (depth): 380 mm  
 Well capacity: 12 It MIN; 14 It MAX  
 Thermostat Range: 100 °C MIN; 180 °C MAX  
 External dimensions, Width: 400 mm  
 External dimensions, Depth: 900 mm  
 External dimensions, Height: 800 mm  
 Net weight: 75 kg  
 Configuration: On Base; One-Side Operated

**Sustainability**

Current consumption: 14.4 Amps

### Included Accessories

### Optional Accessories

- |                                                                                                                                                                                                     |            |                          |                                                                                                                                                                                                                                                                                 |            |                          |
|-----------------------------------------------------------------------------------------------------------------------------------------------------------------------------------------------------|------------|--------------------------|---------------------------------------------------------------------------------------------------------------------------------------------------------------------------------------------------------------------------------------------------------------------------------|------------|--------------------------|
| • Discharge vessel for 14 & 23lt fryers                                                                                                                                                             | PNC 911570 | <input type="checkbox"/> | • Side reinforced panel only in combination with side shelf, for against the wall installations, right                                                                                                                                                                          | PNC 913270 | <input type="checkbox"/> |
| • Lid for discharge vessel 14 & 23lt fryers                                                                                                                                                         | PNC 911585 | <input type="checkbox"/> | • Filter W=400mm                                                                                                                                                                                                                                                                | PNC 913663 | <input type="checkbox"/> |
| • Connecting rail kit for appliances with backsplash, 900mm                                                                                                                                         | PNC 912499 | <input type="checkbox"/> | • Stainless steel dividing panel, 900x800mm, (it should only be used between Electrolux Professional thermaline Modular 90 and thermaline C90)                                                                                                                                  | PNC 913673 | <input type="checkbox"/> |
| • Stainless steel front kicking strip, 400mm width                                                                                                                                                  | PNC 912594 | <input type="checkbox"/> | • Electric mainswitch 25A 4mm <sup>2</sup> NM for modular H800 electric units (factory fitted)                                                                                                                                                                                  | PNC 913676 | <input type="checkbox"/> |
| • Stainless steel side kicking strips left and right, against the wall, 900mm width                                                                                                                 | PNC 912624 | <input type="checkbox"/> | • Stainless steel side panel, 900x800mm, flush-fitting (it should only be used against the wall, against a niche and in between Electrolux Professional thermaline and ProThermetic appliances and external appliances - provided that these have at least the same dimensions) | PNC 913689 | <input type="checkbox"/> |
| • Stainless steel side kicking strips left and right, back-to-back, 1810mm width                                                                                                                    | PNC 912627 | <input type="checkbox"/> |                                                                                                                                                                                                                                                                                 |            |                          |
| • Stainless steel plinth, against wall, 400mm width                                                                                                                                                 | PNC 912897 | <input type="checkbox"/> |                                                                                                                                                                                                                                                                                 |            |                          |
| • Stainless steel plinth, freestanding, 400mm width                                                                                                                                                 | PNC 912916 | <input type="checkbox"/> |                                                                                                                                                                                                                                                                                 |            |                          |
| • Connecting rail kit for appliances with backsplash: modular 90 (on the left) to ProThermetic tilting (on the right), ProThermetic stationary (on the left) to ProThermetic tilting (on the right) | PNC 912981 | <input type="checkbox"/> |                                                                                                                                                                                                                                                                                 |            |                          |
| • Connecting rail kit for appliances with backsplash: modular 90 (on the right) to ProThermetic tilting (on the left), ProThermetic stationary (on the right) to ProThermetic tilting (on the left) | PNC 912982 | <input type="checkbox"/> |                                                                                                                                                                                                                                                                                 |            |                          |
| • Back panel, 400x800mm, for units with backsplash                                                                                                                                                  | PNC 913022 | <input type="checkbox"/> |                                                                                                                                                                                                                                                                                 |            |                          |
| • Stainless steel panel, 900x800mm, against wall, left side                                                                                                                                         | PNC 913102 | <input type="checkbox"/> |                                                                                                                                                                                                                                                                                 |            |                          |
| • Stainless steel panel, 900x800mm, against wall, right side                                                                                                                                        | PNC 913106 | <input type="checkbox"/> |                                                                                                                                                                                                                                                                                 |            |                          |
| • Endrail kit, flush-fitting, with backsplash, left                                                                                                                                                 | PNC 913117 | <input type="checkbox"/> |                                                                                                                                                                                                                                                                                 |            |                          |
| • Endrail kit, flush-fitting, with backsplash, right                                                                                                                                                | PNC 913118 | <input type="checkbox"/> |                                                                                                                                                                                                                                                                                 |            |                          |
| • Filter for deep fat fryer oil collection basin                                                                                                                                                    | PNC 913146 | <input type="checkbox"/> |                                                                                                                                                                                                                                                                                 |            |                          |
| • Endrail kit (12.5mm) for thermaline 90 units with backsplash, left                                                                                                                                | PNC 913208 | <input type="checkbox"/> |                                                                                                                                                                                                                                                                                 |            |                          |
| • Endrail kit (12.5mm) for thermaline 90 units with backsplash, right                                                                                                                               | PNC 913209 | <input type="checkbox"/> |                                                                                                                                                                                                                                                                                 |            |                          |
| • Insert profile d=900                                                                                                                                                                              | PNC 913232 | <input type="checkbox"/> |                                                                                                                                                                                                                                                                                 |            |                          |
| • Energy optimizer kit 18A - factory fitted                                                                                                                                                         | PNC 913245 | <input type="checkbox"/> |                                                                                                                                                                                                                                                                                 |            |                          |
| • Side reinforced panel only in combination with side shelf, for against the wall installations, left                                                                                               | PNC 913268 | <input type="checkbox"/> |                                                                                                                                                                                                                                                                                 |            |                          |